

Part #61

What to Know about Prop Strikes

by Mike Stratman

You've just done the unthinkable! You've managed to splatter your propeller into a thousand pieces when you ran into an unmovable object. While there's little doubt you're going to need a new prop, but what other damage could have occurred to the engine or gearbox?

This month we'll talk about what you can expect as a consequence of a ground contact. Prop strikes can come in a full range of circumstances. All the way from minor tip contact to full blown crank twisting, case busting disasters. We'll set-up a guideline of factors that go into deterring the likelihood of damage to the drivetrain, how to measure certain components to detect damage, and what to do to return the powerplant to full reliability.



Severity of Contact: Before we get started we need to classify the severity of a particular prop strike by category. Just like hurricanes are rated by severity let's call a Category 1 as a garden variety minor strike of a wood prop that splinters a tip of one blade. For our Category 5 propstrike we will use as an example a levee busting full power suicide run of a composite prop into an Oak tree where the engine goes from a high pitched whine to complete silence in a fraction of a second. You get the idea. Obviously the resultant damage is going to vary greatly between the two extremes. Contact made during idle or less than 3000 rpm generally do not produce damage where Cat 5 events may require costly repairs or even engine replacement.

Propeller Construction: What material the prop is made of is a major factor when it comes to what kind of damage can result to the drivetrain. Hardwood or foam core propellers generally shatter on first solid contact. This greatly reduces the forces on gearbox and crankshaft. Serious damage in say Cat 1 thru Cat 2 is unlikely because the loads are dissipated by the fracturing of the wood or foam core. On the other hand composite props are much tougher which means more torque is generated to the drivetrain. If you have a warp drive prop with nickel leading edge commonly found on float planes, you can literally chop fire wood with it. High rpm contact (Cat 4 & 5 events) with this kind of blade is likely to damage the drivetrain severely.



Photo #1 – Check the prop Flange for run out. Maximum of .003" is allowable.

Photo #2 – Check crankshaft at end of taper as shown with roller tipped dial indicator.

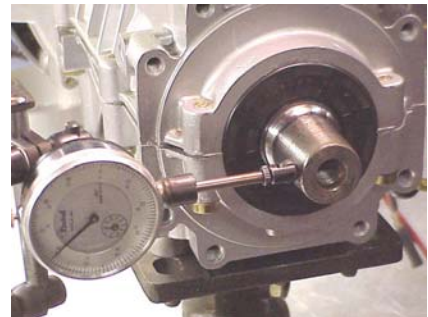

What to look for: First of all, do a full visual inspection of the gearbox housing. Look for cracks in the housing especially around mounting bolts. Remove the remainder of the prop and visually look for a wobble of the prop flange. Measure the run out of the prop flange using a dial indicator parallel to the propshaft close to the outside edge of the flange. This is best done with a roller contact tip fitted to your dial indicator. See photo # .Maximum run out here is .003". If greater than .003" replace propeller shaft.

On two cycle Rotax engines the prop is not hard linked to the crankshaft so crank twisting is usually not an issue in Cat 1-3 events. The knuckle joint in model "B" gearboxes does a good job of protecting the cranks from reasonable shock loads. The Hardy Discs used in the model "C" & "E" gearboxes also soaks up reasonable shock loads. A visual inspection with a flashlight thru the large inspection holes should show if the hardy disc has been torn in anyway. Replace if rubber shows signs of tearing. See Photo #3. The newer C & E Gearboxes come with a #65 or #75 hardness discs (check molded number on disc) that are extremely tough. Older units may be a softer #55 that may tear in more severe prop strikes.



Photo # 3 – The Rubber Hardy Disc protects the crankshaft from shock loads. Check thru large inspection holes in side of model "C" & "E" gearboxes for possible tearing.

Next remove gearbox and measure the PTO crank end. Using the same dial indicator and roller contact tip measure the run out of the crank end as shown in Photo # 2 . Again here the maximum allowable run out is .003" A reading greater than .003" indicates either the crank journals have been twisted or the crank needs to be straighten or replaced. If you choose to continue to run a crank that is greater than .003" out you will likely experience increasing vibration that will eventually lead to the bearings pounding the crankcase till the case is wallered out and needs to be replaced. Not the best economical alternative.

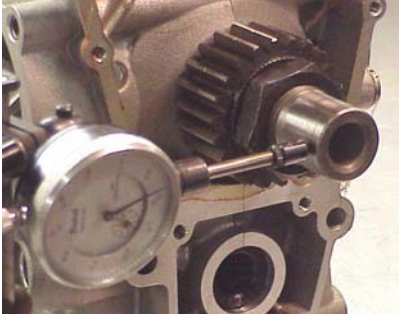

Photo #4 – Check Rotax 912 crankshaft for straightness as shown here. Max. allowable is .003"



Photo #5 – Check housing area between bolt holes and bearing for cracking and bent bolts. See arrow.

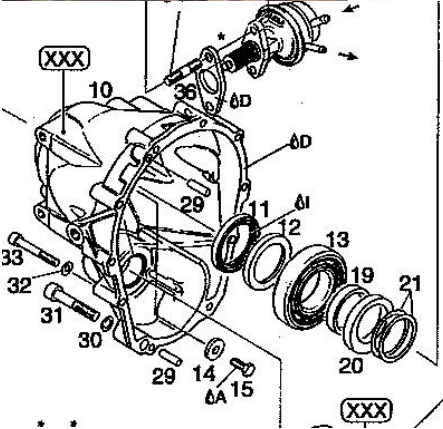

Photo #6 – This drawing from the parts book shows the four 7mm bolts and washers (#15 & #14) that hold the prop bearing in the housing. Bent bolts are a sure sign of prop strikes.

Rotax 912 engines: On the Rotax 912 and 912S engines the crank is much more vulnerable. On older engines not equipped with an overload clutch there is little dampening available to prevent shock loads from being transferred to the crankshaft. Category 4 and 5 events will likely cause the crank to bend or twist resulting in a crank end run out of more than .003" as measured in Photo # 2. Again check the prop shaft run out as shown in Photo # 1 with .003" being the max. acceptable reading. If you detect the propshaft out of spec pull forward section of gearbox housing and inspect the casing surrounding the propshaft bearing (#932-235) in the nose of the housing. See Figure # 6. Four 7mm bolts (#15) and thick washers (#14) hold the bearing in place in the housing. A propstrike can break the housing between the bolts and the bearing. See Photo #5. This is obviously the weakest area of the housing and will crack here if torque is sufficient. Also check the four 7mm bolts #941-760 and washers as they will likely be bent from the shock loads.

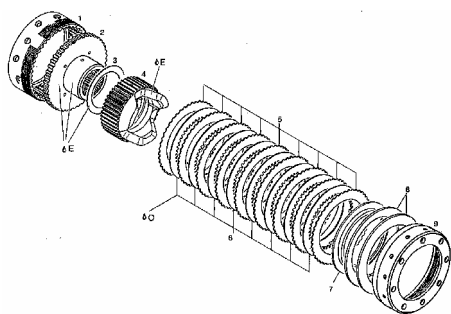

Photo #7 – The overload clutch shown here is now standard equipment on all new 912 series engines. Older engines can be retrofitted for protection from propstrikes and smoother operation.

Rotax 912 Engines with Overload Clutch: All new Rotax 912 and 912S UL engines are now supplied with an overload clutch. This clutch acts similar to an automotive torque converter that allows torsional loads to be dissipated protecting the crankshaft and other drivetrain components. It has always been standard on all certificated Rotax 900 series engines. It can be retrofitted to earlier model engines by a Rotax Service Center or Overhaul shop. See Figure # 6.

Complete engine overhaul is required on all certificated engines as per the Rotax Line Maintenance Manual Part #899-372 section 05-50-00 page #2. (see CPS website at www.800-airwolf.com to download this manual in PDF format free of charge. Go to Tech Info" then "Rotax Engine Manuals" run search for 912 engine and maintenance manual). For UL engines the overhaul is obviously not legally required but following the certificated requirements is highly recommended. Dye penetrate crack testing of crankcase housings is also required for all certificated engines and/or Cat 3-5 events. In most cases these will require the engine to be removed from the aircraft and sent to a qualified Rotax Overhaul Center. Engines equipped with hydraulic governors or vacuum pumps need to have the drive gears checked as well.

Freight Damage: Believe it or not improper packaging and rough handling can cause the prop flange to be bent during transport. If the prop flange is mounted too close to the sidewall of the box a blow to the container may bend the flange and even crack the case surrounding the nose prop bearing as already described. Check the container for signs of prop flange contact immediately when you receive your engine.

Crankshaft Straightening: Crankshafts can be trued if not within spec only by an experienced technician. On a tour of the Rotax assembly line in Austria we witness this procedure. Spinning the crank in a cradle with multiple dial indicators at various locations the technician could spot the which way the crank needed to be "persuaded". Removing the crank from the cradle the guy would do one of three things. Pinch or spread the journals with the use of a hydraulic powered claw or literally whale on it with a huge aluminum hammer in just the right spot. The most amazing part was the guy could turnout 2 to 3 very straight cranks per minute. Wild!! I'm sure that this kind of craft is not easy to find. Crank replacement is probably your best options.

Summary: Every hard core aviator will likely for some reasons fall victim to the dreaded prop strike at some time. . It happens to even the most cautious operators. Hopefully this gives you a some options to consider when your time comes. END