

For Rotax Engines with Bosch or Points Ignition Systems

Reprinted from "The Proper Care & Feeding of the Rotax Motor"May 1989
Ultralight Flying! Magazine

Part #22

Timing The Rotax Motor

by Mike Stratman

Here we are at Part 22 and we have yet to discuss ignition timing in detail. Now that dual CDI ignition is the latest rage, I thought most guys who have standard point ignition systems might start feeling a little left out.

In many ways the old Bosch ignition has advantages over the CDI Systems. Diagnosing problems is much less complex and replacement parts are infinitely less expensive. Replacing CDI components in an effort to pinpoint a faulty part is often the only way out.

The most frequently asked question is, "Can I change my point ignition over to a dual CDI system?" The answer is no!! unless you have lots of money to spend. In most cases the parts will cost more than a new engine.

Having referred to the importance of proper ignition timing many times in the past, it is time to explain this procedure in detail. Having the proper equipment and the knowledge to check and/or set your timing is possibly your best assurance against unsolved mysteries in engine performance. It is a generally accepted rule that when an engine problem is experienced, you first check the ignition timing. By confirming this very precise adjustment, you can only then start looking for other causes. If you don't have this ability, you are obviously at a serious disadvantage when it comes to solving any problem that may arise.

This month we'll discuss in detail the specifications, the proper tools you'll need, what you are trying to control, and why this is vital to optimum engine performance.

Timing an engine involves adjusting the ignition parts to fire spark plugs at the exact moment in the combustion cycle to produce the maximum power and efficiency possible from the engine. The firing of the spark plugs is controlled by the opening and closing of the points at a preset adjustment. All new engines are specially timed at the factory to an exact specification. Due to normal wear on the ignition parts, this specification will fall out of adjustment. The adjustment is determined by the position of the piston in the combustion chamber when the plug fires.

On all Rotax 377, 447 and 503 engines, firing is supposed to happen when the piston is 0.086 inches from the top of its stroke before top dead center (BTDC). On the liquid cooled 532, the setting is 0.077 BTDC. The Rotax 277 setting is 0.100" BTDC, which takes into consideration the dial indicator working at an angle instead of directly above.

Rotax277100" BTDC
Rotax 377, 447, 503086" BTDC
Rotax 532077" BTDC

Some Rotax manuals shows a much broader range of timing, but this is the proper spec called for by the factory on aircraft motors. The final adjustment should be within + or - 0.003 inches. The farther after

(retarded) this setting the plugs fire, the less power is available from the exploding gases, with less than optimum power transmitted to the crankshaft. Severely retarded timing makes an engine difficult, if not impossible, to start. The farther the plugs fire before optimum setting, the more intense the heat on the combustion chamber parts. Intense heat results in detonation, which may cause either partial or complete penetration of the dome. As a result of detonation, the spark plug electrodes turn an intense aluminum color and if you put your finger in the spark plug hole and pull the cord, you will feel no compression at all. Detonation is also signaled by exhaust gas temperatures of 1600-1700 degrees F. which is acknowledged to be the melting point of most aluminum alloys used in modern pistons.

Timing an engine is simple only if you have the proper tools and a complete understanding of what you are trying to accomplish. Don't begin if you are not familiar with what you are doing. You could create more grief than you care to imagine.

Checking and Setting the Timing: If you're only checking the timing, you don't have to remove anything except the spark plugs. Setting the timing involves removing several major parts. Start by removing the recoil starter housing and the plastic fan cover. Next remove the fan pulley by means of the three Allen head bolts. Move the fan belt out of the way but not from its position on the cooling fan. Now you're at the magneto end of the flywheel. After the nut is removed only a press-fit on the tapered end of the crank is holding the flywheel in place. Attach a Puller to the flywheel and remove it. Here is where the proper tools must be used. Rotax makes a specially designed Puller that removes the flywheel without

damaging the threads on the crank, and, at the same time, keeps the crank from turning. The center hub can also be removed, which allows you to remove the large flywheel nut without having the engine spin. Some people are reluctant to spend the money for the factory unit, but if you use your own Puller, be extremely careful not to damage the delicate ignition coils just inside the flywheel.

When using the Rotax factory Puller or any Puller attaching to the three 8mm bolts, care must be taken. If these bolts are installed too far, they will damage the ignition coils just behind the flywheel. If they are installed only a few turns, they may break the cast-iron surface when pressure is applied during removal. Five to six turns not using a wrench is about right. Apply pressure to the main nut in the center of the tool. The flywheel will let go with a bang! Be ready!

To replace the condensers, you will have to remove the entire stator plate assembly by means of the two screws at the top and bottom. It is best to mark the position of the plate for future reference. Use a socket that is just smaller than the condenser to gently tap them out from the back side. They are a press fit only. A drop of Loctite 242, or equivalent, around the condenser or a carefully placed punch mark is a good idea to prevent the condenser from vibrating out of this press fit. In extremely rare cases, a condenser has wandered out far enough to have the wires sawed off by the flywheel. This will allow you a chance to practice your

emergency landing technique.

Older Rotax engines are equipped with a different type of points and condensers than the 1984 and newer engines. The older engines are identified by wires soldered to the condensers. Newer Rotax engines are equipped with wires that are secured to the condensers by a threaded post. Inspect this before ordering replacement parts.

On Rotax 377, 447, and 503 engines, the cam which controls the point opening is on the crank. This allows you to gap the points and set the timing without the flywheel installed. On Rotax 277 and 532 engines the cam is part of the flywheel making it necessary to do your adjusting through the openings in the flywheel. Although the latter is a bit tougher, with a little practice it is really no problem. It also saves you the trouble of removing the flywheel. Insert a dial indicator into the mag-side spark plug hole. You will need a 14mm threaded adapter. Rotate the crank until the indicator shows the piston to be at TDC. The point gap should be 0.015 inches exactly. A 0.014 feeler blade should have some room, while a 0.016" inch blade should have some compression from the points. Do this for both sets of points. Viewing the engine from the recoil end, turn the crank counter-clockwise until the dial indicator shows the proper piston travel (as discussed

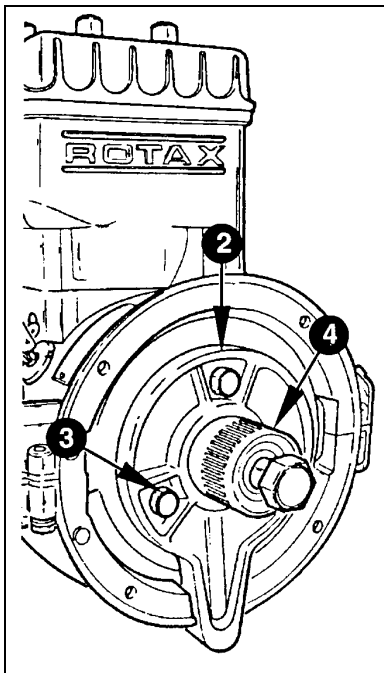

earlier). Install a continuity light between one of the black wires in the wiring harness and an engine ground (See Photo 3). If the engine is timed properly, the continuity light will change in intensity at the proper moment, indicating that the points are opening.

Watch only for a change in light intensity. If you get no reaction, change to the other black wire lead. Each black lead is from one set of points. Determine the exact position of the needle when the light changes intensity, indicating the point at which the plug will fire. This is your engine timing spec. Adjust the timing only if you understand what you are seeing from your timing equipment at this point.

If you have removed the stator plate assembly to install new condensers, rotate the entire stator until the mag side cylinder shows proper timing. The stator should be fairly centered in the adjusting slots. The point gap is at 0.015 inches because you have already set this. Use a screwdriver to secure the two positioning screws of the stator. You will be surprised to find very little change in timing by the movement of the entire stator plate. Once the stator is locked down, move the dial indicator to the power takeoff (PTO) side cylinder and move the continuity light to the other black kill wire. You are now ready to set the timing of this cylinder.

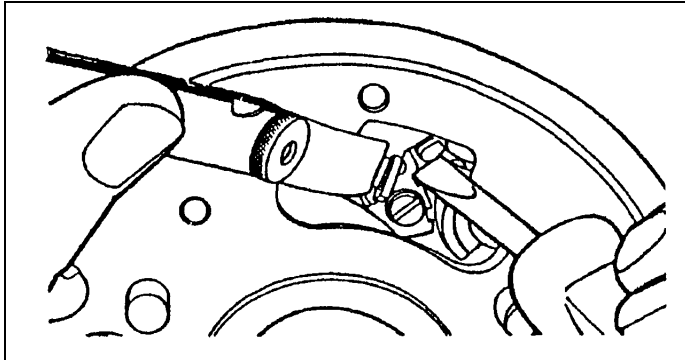

The timing of this cylinder should be reasonably close if you have gapped your points carefully at TDC as previously discussed. The only way to adjust the timing of this cylinder is to change the point gap. For reasons I have never fully understood, the very smallest changes to the point gap make the timing go wild! This is where the fun begins. This is also when you'll be glad that you invested in the proper tools. Leave the lock-down screw as tight as possible on the points, yet light enough to still be able to adjust the point gap with a

screwdriver. Use the special slot on the side of the points for leverage. This is a tedious job because of the sensitivity of the adjustment. You may have to time a little ahead or behind of your mark to compensate for the movement of the adjustment when you lock down the screw. Remember, the final setting is plus or minus .003 inch. This may take awhile if this is your first attempt at this adjustment. Once both points are locked down, check each cylinder again to confirm the accuracy of your work. Do this several times if this is your first attempt.

A Word About Tools: A good dial indicator that screws into a 14mm spark plug hole may cost \$60 or more, and may be extremely hard to find locally. Make sure the Indicator will do the job before you spend the money. Photo 4 shows two indicators equipped with adapters. The top indicator is a unit with a roller attachment needed for timing the Rotax 277. The roller allows the indicator to work at the angle of the spark plug. Note the long extension needed to reach the piston dome. The 503 also requires special extensions to reach it.

A continuity light is a simple device. Unfortunately, the \$3 ones that the auto parts stores sell are sometimes useless. What you are looking for is a subtle change of intensity. If you can barely see the light you will be hard pressed to recognize what you are looking for. Pay a little more for this item and your task will be much easier to perform. "Buzz boxes" are sometimes used in place of a continuity light to determine point openings. A change in the buzzing indicates a change in continuity or light intensity. While this is every bit as accurate as the light, these things are expensive. It is hard to justify purchasing one unless you make your living timing 2-cycle engines. You may use an ohm meter only if set to the right range. Test to make sure you can recognize what you are looking for before starting your timing procedure.

Summary: The only way to appreciate the complexity of properly timing an engine is to do the job yourself or watch a qualified service center do it. It's surprising how delicate this adjustment is and how easy it is for high-time engines to fall out of timing through normal wear of ignition parts.

Source: Part22 Timing the Rotax