

For Timing Rotax Engines with Ducati CDI Ignition Systems

Reprinted from "The Proper Care & Feeding of the Rotax Motor"
Ultralight Flying! Magazine

Part #39

Timing The Ducati Ignition

by Mike Stratman

Yes!, that's right!, just when you thought it was safe to put your timing tools away, here comes the new style Ducati Ignition. Due to some recent changes to the ignition systems on Rotax 447, 503, 582, and 618 motors setting the ignition timing is now a requirement when reassembling these engines. Certain parts, by their design, have adjustable features built in to them. Notice I said "when reassembling". In order to service the crankshaft area the trigger coils must be removed and reset. It is important to note this system is still a maintenance free set up or in other words the parts do not wear out nor do they need to be replaced as part of normal maintenance. This month we will clarify the production changes made by Rotax, how to identify them, and the procedures and specs necessary to set them properly.

Why the Change?: The first subject that needs to be addressed is the basic question of "why did they have to change this". If you real understand the exacting nature of ignition timing on two cycle engines, you will accept the fact that a non-adjusting system is not totally desirable. What happens if the timing is off on a non-adjusting system? Your simply cannot adjust the timing to suit your needs. The triggering parts used on the older style fixed system were mounted on holes cast into the crankcase. These holes determined the timing spec by their location in the crankcase. From a production stand point this makes for some rather exacting specs for both the triggering parts, mounting hardware, and the crankcase itself. In retrospect it can be safe to conclude that the older style fixed system was bound to have problems, thus the changeover to the new adjustable system.

How to Identify The Two Type of Ignition Systems: This is easy. The older style Trigger Coils had

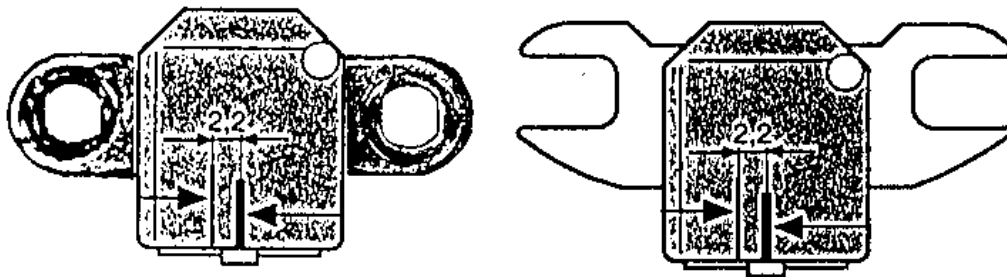

Figure # 1 - Old Style Trigger Coils (shown on left) did not allow the timing to be adjusted. The new Style Trigger Coils (right) are slotted in two directions for a full range of adjustment.

range of rotational adjustment as well as air gap adjustment. See illustration for clarification. By the way, if you want to buy the old style, Sorry!, Rotax subs all part numbers over to the new style only.

mounting ears with holes that were round and horizontal slotted. The round hole acted like a fixed pivot point while the horizontal slot allowed the air gap to be adjusted in and out. The new style have both ears vertically slotted. This allows for a full

How the Ducati System Functions: The Ducati system fires the plugs by means of a breakerless magnetically triggered pick up coil. Two magnets are located on the flywheel at exactly 180 degrees opposed. As the leading edge of the magnet meets the leading edge of the trigger coil bar, the signal is sent to fire the plugs. The position of the trigger coil in relation to the flywheel (and thus the piston travel) determines the engine timing spec. Because there are two magnets, all four plugs fire at both top and bottom of the piston stroke. The bottom stroke fire has little or no effect on combustion because there is virtually nothing left in the chamber to burn.

How to Set the "Air Gap": I've referred to the air gap a couple of times without explaining what it is. The distance between the trigger coil and the magnet is a critical measurement due to the breakerless design of the system. On either system, old or new style, this distance must be 0.020" + or - .002" when the final adjustment is made.

Figure # 2 - Whether you have old or new style Trigger Coils, the air gap must be set as shown. Spec is 0.020" gap + or - 0.002".

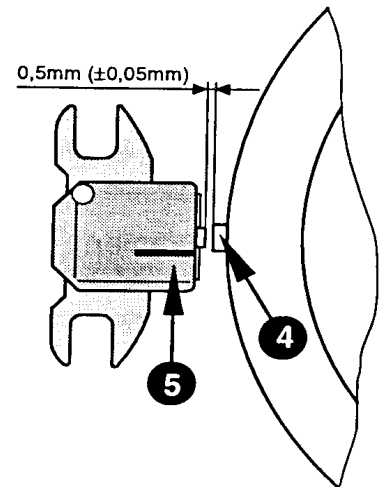

Rotax - Ducati Timing Specifications

Rotax 447 .086" BTDC	no offset	(no compensation needed)
Rotax 503 .069" BTDC	offset 30 degrees	(compensation included)
Rotax 582 .076" BTDC	offset 11 degrees	(no compensation included)
Rotax 618 .058" BTDC	offset 11 degrees	(no compensation included)

Figure #3 - The proper timing spec for all Ducati engines + or - .003" . Due to the plug angle used on some engines the actual figure is adjusted as needed.

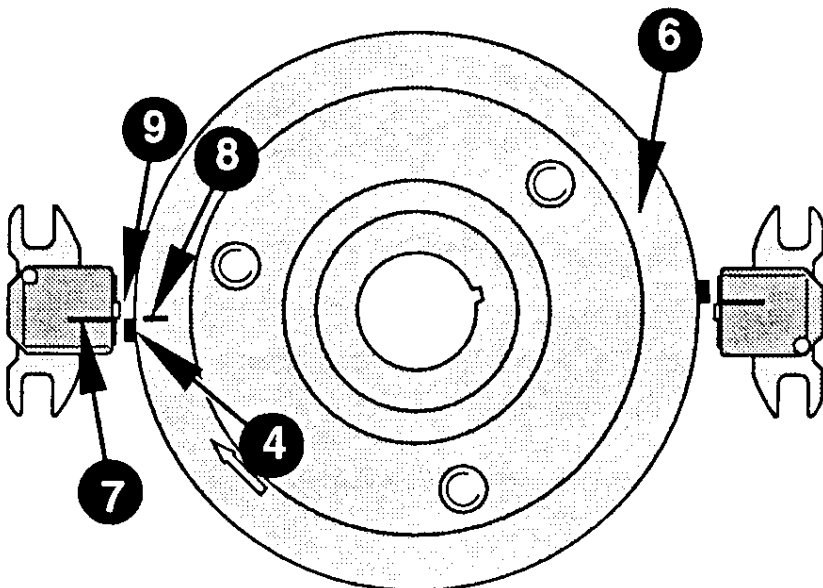

Figure # 4 - Note the position of trigger coils versus the leading edge of the flywheel magnets. This is the point at which the plugs will fire. This must occur at the point shown in chart - figure #3.

How to Set the Timing: Install a dial indicator through the spark plug hole and find top dead center. Zero out the dial at this point. Rotate the engine counter clock wise (as you view the flywheel end) until you reach the spec shown in figure #3. This is the point at which the leading edge of the flywheel magnet and the leading edge of the trigger coil are directly across from each other. See illustration provided. This is the point at which the plugs will fire. Because Ducati engines are designed with a variety of spark plug angles that are not parallel with piston travel the compensation for angles are included in figure #3 as shown. If the position of the trigger coils are not at the proper position loosen the mounting screws and position the trigger coil as

needed. Do this to both trigger coils while the piston is in the same position. Because the flywheel magnets are precisely 180 degree opposed and the plugs fire at both top and bottom stroke, both triggers can be set at once. Remember the air gap (0.020" + or - .002") must be maintained when the parts are directly across from each other.

To check your timing and your crankshaft for twist, move the dial indicator to the other cylinder and set for top dead center. Again because the flywheel magnets are precisely 180 degrees opposed the timing should still be the same (assuming the accuracy of your dial indicator and your procedure) regardless of which trigger coil you are checking. All Rotax crankshafts are a press fit only design. While this design has proved to work quite well and it is very rare for a crank to twist under normal operating conditions, a good prop strike will do the job nicely. The only reason for a substantial error between cylinders would be a twisted crank. This twist must not exceed .002" on the dial indicator.

When to Check the Timing: As with any two cycle engine, correct engine timing is crucial. Whenever you experience a performance problem, check the ignition timing. Get rid of the variable. Yes, I know it's not suppose to change as long as the fasteners remain tight, but any good mechanic will assume nothing and start with the basics when diagnosing trouble. Whenever you service the crankshaft the crankcases must be split, requiring you to remove the trigger coils, disturbing the timing. Follow the procedure outlined above.

Proper Ignition Timing Tools: If you have upgraded from the old breaker point Rotax, then you probably have the dial indicator, adapters, and extensions. If you do not own this equipment, you will eventually did it to do any serious engine work or diagnostic procedures. It is advisable to always use a roller contact kit whenever working in a plug hole that is not parallel to the piston travel. The roller contact option does two things, adds enough extension to reach most any piston and protects the indicator while working at an angle. See illustration for the proper equipment needed to time Ducati motors.

And there you have it. While the idea of a non-adjustable ignition timing sounded like a great idea, time marches on. Those of you with the old style trigger coils might want to see what your timing is set at just for grins. I'd be interested to know how close they come out to the published spec. It is important to note that unlike the old breaker point engines, there is no parts to wear out and no reason for the timing to vary under normal operating conditions. A big improvement in simplicity and reliability.

source: part 39 Ducati Timing